

# SRS Button LED

## System Requirements Specification



Status: Draft

Author: automatically generated from the SiSy model

### Table of contents

1	Purpose .....	2
2	Overall description of the task.....	2
3	Functional requirements.....	2
4	Hardware requirements.....	3
5	Process requirements .....	3
6	Attachment .....	5



## 1 Purpose

All elements of this project are parts of a course for the professional development of embedded systems. This Embedded Systems Engineering course is intended to develop a broad interdisciplinary understanding and knowledge of the participants as well as to develop practical skills for the realization of embedded systems.

The hardware platform for this course is the mySTM32 Board lite. It has a microcontroller of the STM32 family and all required input and output devices or add-ons.

## 2 Overall description of the task

A microcontroller application is to be developed in which a new function is selected by clicking a button and visualized by means of an LED blink code.

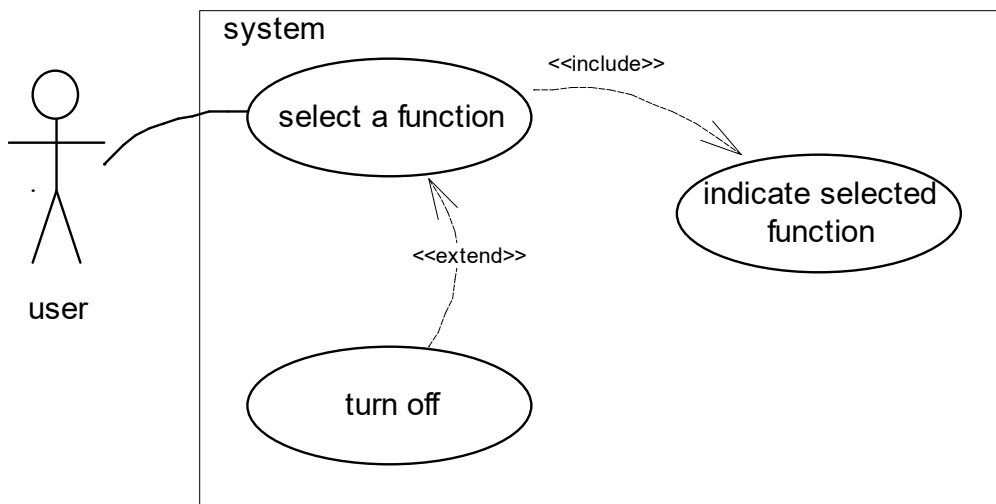

figure 1: uc: Button LED tasks, user's perspective

List of top level requirements:

- system: select a function
- system: turn off
- system: indicate selected function

## 3 Functional requirements

At system start the display LED is off. If the user briefly presses (click) the function key, a indicator LED should show a blink code. With every further click the blink code of the ad should be counted again. 1 time click = blink code 1, 2 times click = blink code 2, 3 times click = blink code 3, etc. If the user presses the function key for a long time (hold for 2 seconds) the indicator LED is to be switched off.

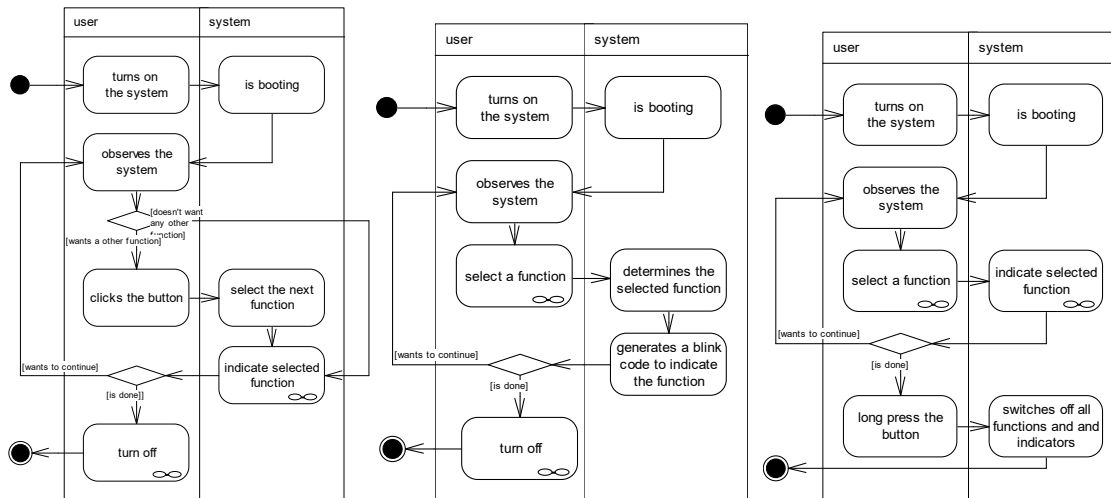

figure 2: activity models: select a function, indicate selected function, turn off

## 4 Hardware requirements

The hardware platform for this course is the mySTM32 Board lite. It has a microcontroller of the STM32 family and all required input and output devices or add-ons.

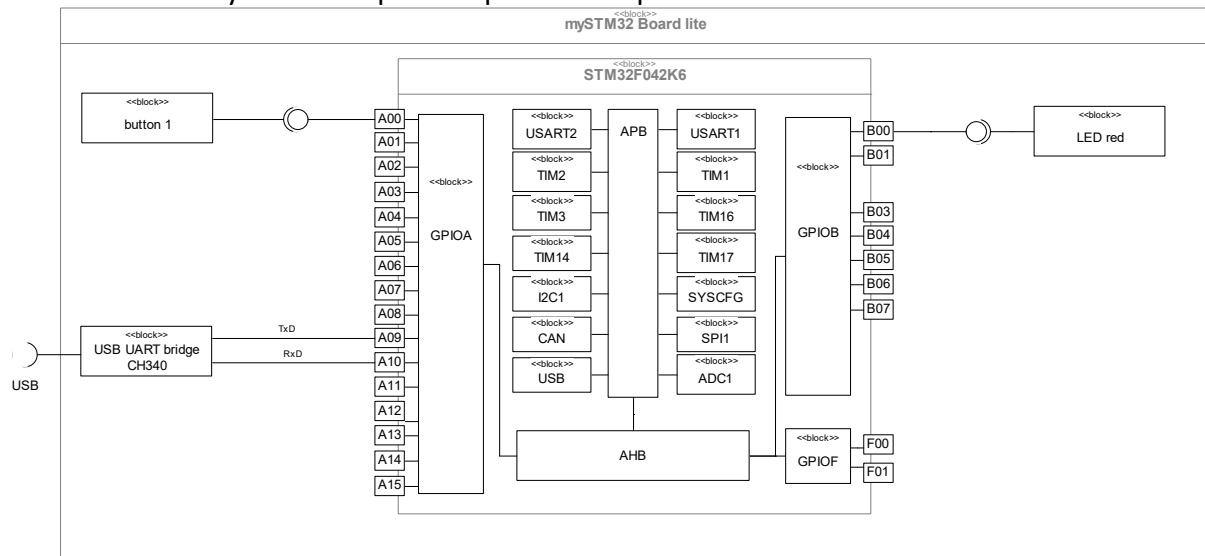

figure 3: Button LED HRM

- connected pinB0 : LED red
- connected USB
- connected pinA0 : button 1

## 5 Process requirements

A software process is the defined sequence of activities, the agreed rules, techniques, tools and the expected results of the activities for the production of software. Defined software processes ensure the plannability, controllability and quality of results in the manufacture of software. The following simple software process is agreed as a binding workflow for this course.

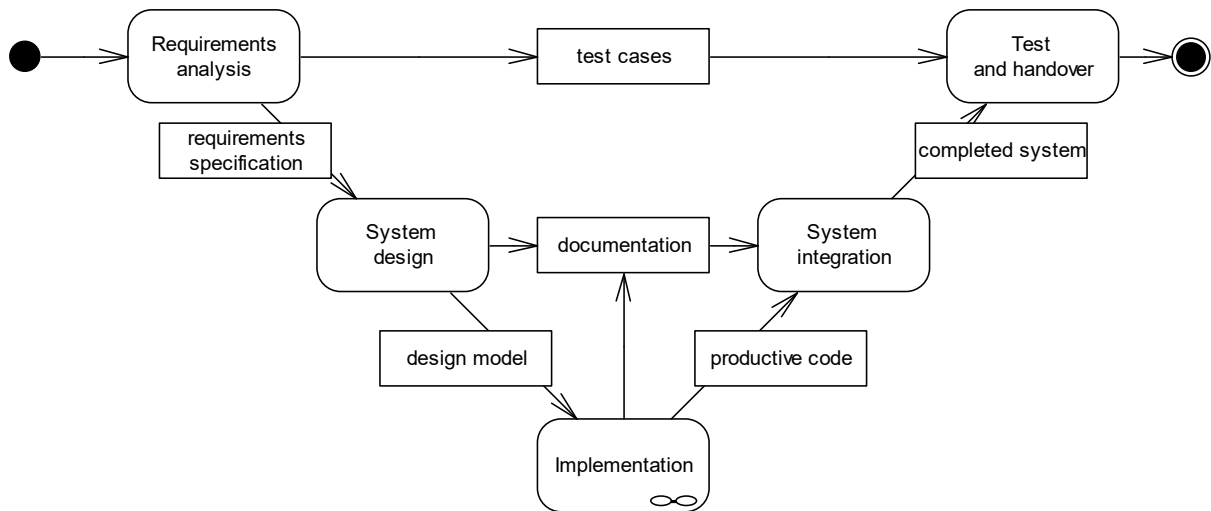

figure 4: act: lightweight model driven embedded software process

table 1: lightweight model driven embedded software process

Activity	Expected results
Requirements analysis	<ul style="list-style-type: none"> <li>- User's perspective as use case diagram (as SysML / UML model)</li> <li>- required functionalities as activity diagrams (as SysML / UML model)</li> <li>- Test cases (as a document)</li> <li>- HRM hardware resource model (as SysML model)</li> <li>- SRS System Requirements Specification (as a document)</li> </ul>
System design	<ul style="list-style-type: none"> <li>- Class model of the concept level / architecture model (as UML model)</li> <li>- if necessary, state model (as UML model)</li> <li>- System documentation (as a document)</li> </ul>
Implementation	<ul style="list-style-type: none"> <li>- Class model of the realization (as UML model)</li> <li>- Behavioral models of the realization (as UML model)</li> <li>- Productive code (as a transferable format of the target platform, * .hex, * .elf)</li> <li>- System documentation (as a document)</li> </ul>
System integration	<ul style="list-style-type: none"> <li>- hardware software integration</li> <li>- the completed system</li> </ul>
Test and handover	<ul style="list-style-type: none"> <li>- the tested system</li> <li>- the technical system documentation (as a document)</li> <li>- the user documentation (as a document)</li> </ul>



## 6 Attachment

### List of figures

<i>figure 1: uc: Button LED tasks, user's perspective .....</i>	<i>2</i>
<i>figure 2: activity models: select a function, indicate selected function, turn off .....</i>	<i>3</i>
<i>figure 3: Button LED HRM .....</i>	<i>3</i>
<i>figure 4: act: lightweight model driven embedded software process.....</i>	<i>4</i>

### List of tables

<i>table 1: lightweight model driven embedded software process .....</i>	<i>4</i>
--	----------